

Honeywell

enviraire®

Portable HEPA Air Cleaners

READ AND SAVE THESE INSTRUCTIONS

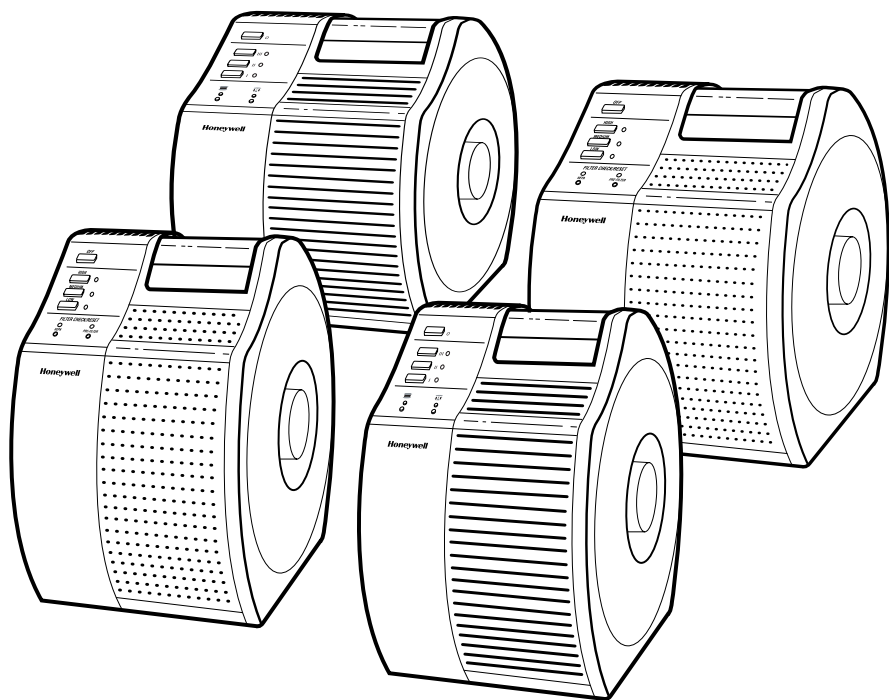

Owner's Guide

For Model Series
17000 Air Cleaners

The Science of Clean Air™

Important Safety Instructions...

PLEASE READ ALL INSTRUCTIONS BEFORE USING THIS PRODUCT. Save these instructions for easy reference.

When using electrical appliances, basic precautions should always be followed to reduce breakage, risk of fire, electric shock and injury to persons including the following:

1. Read all instructions before operating the air cleaner.
2. Place air cleaner where it is not easily knocked over by persons in the household.
3. Always unplug when not in use.
4. Do not use any product with a damaged cord or plug or if product malfunctions, is dropped or damaged in any manner. Keep the cord away from heated surfaces.
5. Do not use air cleaner outdoors.
6. Never use air cleaner unless it is fully assembled.
7. Do not run power cord under carpets, and do not cover with throw rugs. Arrange cord such that it will not be tripped over.
8. Do not use air cleaner where combustible gases or vapors are present.
9. Do not expose the air cleaner to rain, or use near water, in a bathroom, laundry area or other damp location.
10. To disconnect the air cleaner, first turn the air cleaner OFF and remove plug from the outlet.
11. The air cleaner must be used in its upright position.
12. Do not allow foreign objects to enter ventilation or exhaust opening as this may cause electric shock or damage to the air cleaner. Do not block air outlets or intakes.
13. Locate air cleaner near power outlet and avoid using an extension cord.
14. The air cleaner has a polarized plug (one blade is wider than the other). To reduce risk of shock, this plug is intended to fit in a polarized outlet only one way. If the plug does not fit fully in the outlet, reverse the plug. If it still does not fit, contact a qualified electrician. **DO NOT** attempt to defeat this safety feature.
15. A loose fit between the plug and the AC outlet (receptacle) may cause overheating and a distortion of the plug. Contact a qualified electrician to replace loose or worn receptacles.
16. Do not sit, stand or place heavy objects on the air cleaner.
17. Disconnect power supply before servicing.
18. **WARNING:** To reduce risk of fire or electric shock, do not use this product with any solid-state speed control device.

Congratulations...

You now own a quality portable HEPA air cleaner that has been engineered and crafted for your satisfaction.

Honeywell air cleaners incorporate a true HEPA filter. HEPA is an acronym for *High Efficiency Particulate Air*.

Our Consumer Relations representatives will be pleased to help with any questions or concerns you may have about your **Honeywell** air cleaner. Please call our Consumer Relations Dept. at (800) 332-1110 for assistance.

For Best Performance ...

We recommend that you operate your **Honeywell** air cleaner 24 hours a day because indoor air can be quickly contaminated by activity in a room and infiltration of outside air. While all the air in a room will not be processed by the air cleaner, the more air circulated through the filter, the more filtered air returned to the room. Portable air cleaners will be much more effective in rooms where all doors and windows are closed.

For models that include a CPZ™ odor and gas adsorbing filter(17250 and 17450 series), carefully remove the plastic bag which protects the CPZ™ filter during shipment before operating your air cleaner. Your air cleaner will not operate properly with the plastic bag in place, and it may damage the air cleaner. The plastic bag may contain small particles and dust caused by vibration of the CPZ™ filter during shipment. Use care to avoid soiling clothing, carpets and other furnishings with the particles or dust.

The **Honeywell** HEPA air cleaner can be placed on the floor in almost any location. However, for best performance the air outlet slot should not be blocked for at least 3 feet (1 meter) in all directions.

Due to the large volume of air drawn towards the air cleaner, surrounding areas should be cleaned and/or vacuumed frequently to prevent build up. This may help keep your home cleaner and may extend the life of your prefilter. If the unit is placed on a light colored carpeting, a small mat or rug should be used to ease cleaning and prevent any permanent staining. This is particularly important in homes with heavier contamination from smoking or fireplaces.

Construction ...

Your **Honeywell** air cleaner has five basic components: the locking mechanism, the endcap, the HEPA filter, the activated carbon pre-filter, and the base assembly (with controls and motor).

Models 17250, 17450 Series

Your **Honeywell** air cleaner has six basic components: the locking mechanism, the endcap, HEPA filter, CPZ™ odor and gas adsorbing filter, activated carbon pre-filter, and the base assembly (with controls and motor).

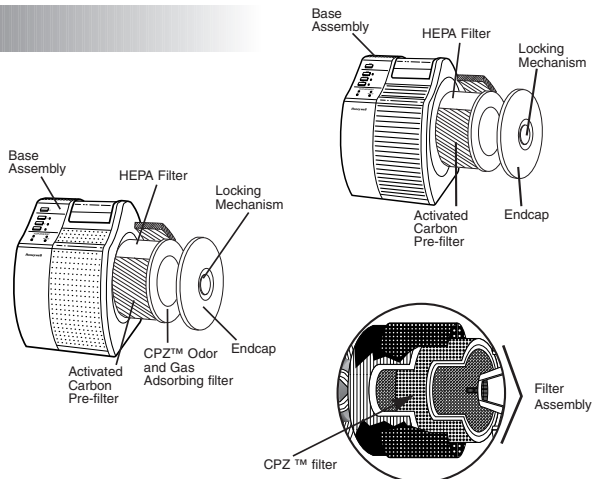

17000 Series...

The **Honeywell** 17000 series air cleaners are 3 speed air cleaners operated by turning the unit on high for a few seconds, and then leaving it on high for faster, more powerful air circulation, or moving it to a lower setting as desired.

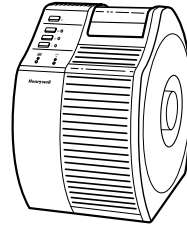

Filter Check/Reset Monitors

The 17000 series air cleaner is equipped with electronic controls and Intelli-Check™ Filter Monitors to serve as a convenient reminder when to replace the pre-filter and HEPA filter. The filter monitors will begin counting the hours of use once the unit is powered on.

The Intelli-Check™ Filter Monitors will count the hours of filter use based on the unit's operating speed, and will indicate when the filter's expected life has been reached. This is beneficial because the expected life of a filter depends on the amount of air and contaminants drawn through it. Once each filter has reached its expected life, its light will remain on until it is RESET. You may unplug the air cleaner without interrupting the hours counted.

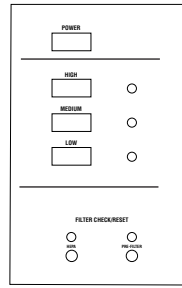

CHECK Expected Filter Life Usage.

To check the amount of expected filter life used, quickly press the filter monitor button when the unit is turned on. It will flash up to 3 or 4 times, depending upon how much expected filter life has been used. The filter monitors are intended as guidelines only, as individual use may vary.

Check Pre-filter life used by quickly pressing the pre-filter monitor button:

1 Flash	2 Flashes	3 Flashes	
NEW	2/3 life remains	1/3 life left remains	Replace 900 Hours*

Check HEPA filter life used by quickly pressing the HEPA filter monitor button:

1 Flash	2 Flashes	3 Flashes	4 Flashes	
NEW	3/4 life remains	1/2 life left remains	1/4 life left remains	Replace 6,000 Hours*

*If operated an average of 12 hours a day on medium speed, the filter monitor light will indicate replacement in about 3 months for the pre-filter, and about 1 year and 9 months for the HEPA filter.

NOTE: If operated on a higher speed for a greater number of hours each day, the filter light monitors will indicate replacement sooner than if operated on a lower speed for fewer hours each day.

RESET Filter Monitor After Filter Replacement.

When the filter monitor light remains on, it is time to replace the filter. Once the filter has been replaced, you must reset the filter monitor. With the unit powered on, press the filter monitor button down for a 5 second delay. The light will turn off.

Replacement Filters...

Use only genuine Honeywell replacement filters designed for these units. Select the proper replacement filter for your **Honeywell** HEPA Air Cleaner from the chart below:

<u>Model No.</u>	<u>HEPA Filter Part Number</u>	<u>Carbon Pre-filter Part Number</u>	<u>CPZ™ Kit</u> (includes 2 prefilters)
17000	20500	32002, 38002	NA
17200	21500	32000, 38002	NA
17250	28720	32002, 38002	21200
17400	22500	33002, 38002	NA
17440	22500	33002, 38002	NA
17450	28725	33002, 38002	22200

Replacement filters may be purchased from the retail store or ordered from the dealer where you purchased the product. If you cannot locate one in your area please call our Consumer Relations Dept. at (800) 332-1110 for assistance.

When to Replace Filters

RESET THE FILTER MONITOR ONCE EACH FILTER HAS BEEN REPLACED.
See “**Filter Check/Reset Monitors**” section for further details.

For model 17250 and 17450 series, after replacing the CPZ™ filter, use the enclosed CPZ™ filter reminder label to indicate the next time the filter is to be replaced (approximately every six months).

CAUTION: Do not attempt to wash either the activated carbon pre-filter, the HEPA filter or the CPZ™ filter. They are not washable and washing will damage the filters.

With proper maintenance, your **Honeywell** air cleaner is designed to provide years of high efficiency air cleaning. Your Honeywell air cleaner contains two filters: one activated carbon pre-filter and one primary HEPA filter. Models 17250 and 17450 contains three filters: one activated carbon pre-filter, one primary HEPA filter, and a CPZ™ odor and gas adsorbing filter.

The activated carbon pre-filter captures lint and other large particles and helps protect the HEPA filter. It also helps reduce common household odors. The pre-filter should be replaced at least every 3 months. You may need to replace the pre-filter more often if the unit is used in a smoking environment or if unpleasant odors persist. We **DO NOT** recommend operating the air cleaner without the activated carbon pre-filter or without following the filter replacement guidelines.

The primary HEPA filter should remain effective for 1 to 3 years, depending upon the environment in which the air cleaner is operating. Honeywell recommends changing the HEPA filter based upon operation conditions-every 3 years for light usage, 2 years for normal usage and 1 year for heavy usage.

The CPZ™ Filter Cartridge should be replaced at least every 6 months. Filter life depends upon condition of use.

Our recommendations regarding filter replacement intervals are intended as guidelines only. Life expectancy of any filter media is dependent on the concentration of the contaminants to which the system is exposed. If there are sources of large amounts of contaminant generation (such as woodworking or heavy smoking) the useful life of the filter media in your air cleaner may be reduced.

Whenever the air resistance of the HEPA filter becomes excessive due to the amount of contaminants it has captured, the air volume output will begin to reduce and the sound level of the air cleaner will increase somewhat. A completely blocked filter will cause a loud rumbling sound and almost no airflow.

How to Change the Filters...

CAUTION: TURN OFF THE AIR CLEANER AND DISCONNECT FROM POWER SUPPLY BEFORE SERVICING

The only two parts requiring any service are the activated carbon pre-filter and the HEPA filter (also CPZ™ filter on 17250 and 17450 model series). No tools are needed. To change either filter, disassemble the unit as shown.

1. Turn off the air cleaner and disconnect from power supply.
2. Loosen the locking mechanism by turning it counterclockwise and remove the endcap from the unit (Fig. 1).
3. Remove the HEPA filter, (CPZ™ filter on 17250 and 17450 model series) and activated carbon pre-filter from the base assembly (Fig. 2).
4. Remove the fasteners from the activated carbon pre-filter and remove it from the HEPA filter cartridge (Fig. 3).
5. Replace filter(s) as needed, and discard used filter(s).
6. Wrap the activated carbon pre-filter around the HEPA filter cartridge and secure it with the fasteners provided.

Reassemble your **Honeywell** air cleaner as described below:

1. Place the assembled HEPA filter, (CPZ™ filter on 17250 and 17450 model series) and the activated carbon pre-filter in the base assembly.
2. Replace the endcap onto the unit.
3. Reattach the locking mechanism and turn it clockwise until securely tightened.
4. Plug into a wall outlet.
5. Turn unit ON and RESET filter monitor(s) for filter(s) replaced by pressing the appropriate filter reset button(s) for a 5 second delay (Fig. 4).

Note: For model 17250 and 17450 series, after replacing the CPZ™ filter, use the enclosed CPZ™ filter reminder label to indicate the next time the filter is to be replaced.

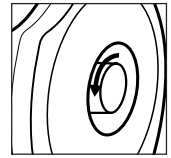

FIG. 1

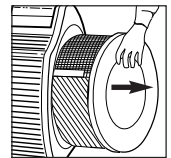

FIG. 2

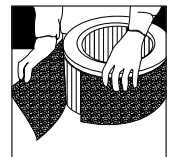

FIG. 3

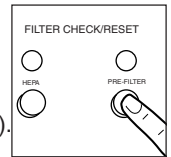

FIG. 4

If the Air Cleaner Does Not Operate...

- Check to make sure that the power cord is correctly connected to the outlet.
- Test that the outlet is functioning properly using another appliance or lamp.
- Check the fuse or circuit breaker. The outlet may be overloaded if other appliances are also in use. Determine and correct the cause of the overload.
- If none of the above procedures restore operation, return your unit to the store or if the store's return policy does not allow, return the complete unit per the instructions in the warranty section of this owner's guide. Do not attempt to repair the unit yourself.

Storage...

If you store your **Honeywell** HEPA air cleaner for more than 30 days, we recommend:

- Remove both the primary HEPA filter and the activated carbon pre-filter from the unit. Also remove CPZ™ filter in model 17250 and 17450 series.
- Discard the pre-filter. Discard the CPZ™ filter (in model 17250 and 17450 series only).
- Wrap the HEPA filter in an air-tight plastic bag or plastic wrap. Be sure that the filter is totally sealed.
- To restore the air cleaner to service, unwrap the HEPA filter, install a new activated carbon pre-filter, and CPZ™ filter (model 17250 and 17450 series), and replace the filters in the air cleaner. See "How to Change the Filters..." section for proper installation.

5 Year Limited Warranty...

Honeywell HEPA Air Cleaners

Model Nos. 17000 Series

This product has been engineered and crafted with great care for your satisfaction. **Be sure to fill out and return the enclosed card within 7 days of purchase.**

A. This limited warranty applies to repair or replacement of product found to be defective in material or workmanship within 5 years of the date of purchase. This warranty does not apply to damage resulting from commercial, abusive, unreasonable use or supplemental damage. Defects that are the result of normal wear and tear will not be considered manufacturing defects under this warranty. HONEYWELL IS NOT LIABLE FOR INCIDENTAL OR CONSEQUENTIAL DAMAGES OF ANY NATURE. ANY IMPLIED WARRANTY, INCLUDING MERCHANTABILITY OR FITNESS FOR A PARTICULAR PURPOSE, ON THIS PRODUCT IS LIMITED IN DURATION TO THE DURATION OF THIS LIMITED WARRANTY. Some jurisdictions do not allow the exclusion or limitation of incidental or consequential damages or limitations on how long an implied warranty lasts, so the above limitations or exclusions may not apply to you. This warranty gives you specific legal rights, and you also may have other rights which vary from jurisdiction to jurisdiction. **This warranty applies only to the original Purchaser of this product.**

B. At its option, Honeywell will repair or replace this product if it is found to be defective in material or workmanship within the limited warranty period. Defective product should be returned to the place of purchase in accordance with store policy or to Honeywell.

C. This warranty does not cover damage resulting from unauthorized attempts to repair or from any use not in accordance with this manual.

D. This warranty **DOES NOT** cover the pre-filter, HEPA filter, or CPZ™ filter except for material or workmanship defects.

E. Return defective product to the following address with a brief description of the problem. Include proof-of-purchase and a U.S. \$10.00 / Canadian \$13.00 check or money order for handling, return packing and shipping charges. Please include your name, address and daytime phone number. You must prepay shipping charges. Mark carton **"Attention Repair Department"**
Ship to:

Honeywell Consumer Products
4755 Southpoint Drive
Southpoint Distribution Center
Memphis, TN 38118
U.S.A.

Honeywell Consumer
Products Canada
510 Bronte St. South
Milton, Ontario Canada L9T 2X6

If you experience a problem with your air cleaner, please see owner's guide for instructions. Please do not attempt to repair the air cleaner yourself. Doing so may void the warranty and could cause damage or personal injury. If the problem still persists, please call:

Honeywell Inc.
Consumer Relations Dept.
Toll Free 1-800-332-1110.

Mail Questions or Comments to:

Honeywell Inc.
Consumer Relations Dept.
250 Turnpike Road
Southborough, MA 01772
U.S.A.